

Installation of Bi-facial
Photovoltaic Cell module of
Tongwei Solar (Hefei) Co.,
Ltd.

List of Applicable Products

Photovoltaic Cell type	Product model
210 mono crystalline cell	TWxxxMBCP-132-D (xxx=630-675)
	TWxxxMBCP-120-D (xxx=575-610)
182 mono crystalline cell	TWxxxMBAP-144-D (xxx=520-555)
	TWxxxMBAP-120-D (xxx=450-460)
	TWxxxMBAP-108-D (xxx=390-415)

Friendly reminder: Photovoltaic modules in this installation manual are only allowed to be installed below 2000m above sea level.

Contents

Purpose of the manual	02
Disclaimer	02
Safety and transportation	03
Mechanical installation	07
Electrical installation	14
Grounding	16
Bypass diode and anti-reverse diode	17
Maintenance	18

Purpose of the manual

This manual is only applicable to bi-facial photovoltaic cell modules (hereinafter referred to as "modules") of Tongwei Solar (Hefei) Co., Ltd.(hereinafter referred to as "Tongwei"). This manual covers the installation method, operation safety and maintenance information of Tongwei modules.

Modules must be installed by professionals. Please read this manual carefully before installation. The installer must strictly abide by the manual, local laws or relevant requirements and regulations of authorized institutions.

Before installation, the installer must be familiar with the mechanical and electrical requirements during installation. Please keep this manual in a safe place so that it can be consulted in future service and maintenance, as well as sales or disposal of modules.

Disclaimer

Tongwei shall not bear any related losses caused by the installation, operation, use or maintenance of modules in violation of the requirements of the manual. Including module collapse or damage or other expenses.

No customer may obtain a patent or patent license by using this module (express or implied). Any relevant liabilities arising from infringement of patent or other rights of a third party by using this module are not within the scope of Tongwei's liability. The information in this manual is based on Tongwei's knowledge and experience, and the content is reliable. However, the product specifications (but not limited to) and related suggestions contained herein do not constitute any express or implied warranty.

Tongwei reserves the right to change the manuals, modules, specifications or other information without prior notice.

Safety and transportation

General rules

- Before installation, ensure that all modules and electrical connectors are clean and dry.
- Handle modules with both hands. Stacking modules is prohibited.
- Special care should be taken when handling modules. Please use slip proof gloves.
- Please use unpacking tooling when unpacking.
- The application level of Tongwei module is Class A, which can be used in systems above $> 50V$ DC or 240W.



Do not tread on the modules.



Do not disassemble or throw modules. Removal of labels or components off the module is prohibited.



Do not use mirrors or magnifying glasses to concentrate sunlight on the modules.



Do not lift the module by grasping the junction box or cable.



Do not touch the module with any sharp objects.



Do not apply pressure directly to the front glass or back panel of the module.



Do not touch the coated glass surface with your bare hands.



Ensure all electrical contacts and operating environment are clean and dry.

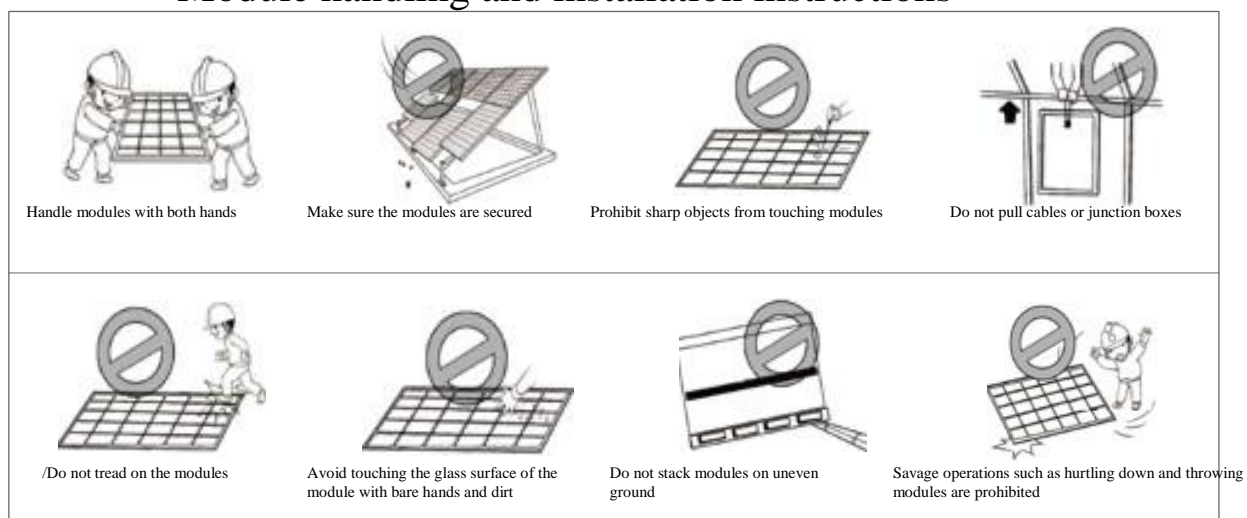

Module handling and installation instructions



Safety and transportation

Packaging labeling instructions

Please read the unpacking instructions and the outer packing box label carefully before operation, and operate according to the label requirements.

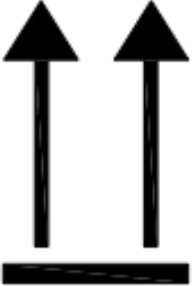
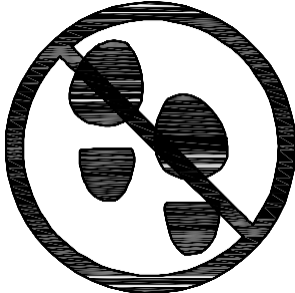
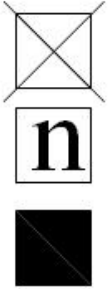
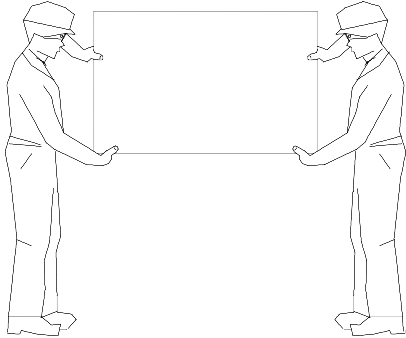
<p>1. Prevent the modules from getting wet or moisture.</p> 	<p>2. The modules in the carton are fragile, handle with care.</p> 
<p>3. The package shall never be upside down during the transportation.</p> 	<p>4. Do not tread on the packing boxes and modules</p> 
<p>5. When stacking modules, do not exceed the maximum number of layers printed on the outer packing box (when n=2, stack max up to 2 layers)</p> 	<p>6. One module needs to be carried by 2 people at the same time</p> 

Safety and transportation

Unloading, transportation and storage

- After the modules arrive at the project site, the freight car should stop and unload in a flat and open area.
- Forklift unloading: Choose a forklift truck with suitable load according to the weight of the goods, unload the modules from the truck, and place the modules on the horizontal ground.
- Crane unloading: Fix the lifting belt in the buckle of solid wood support frame (Figures 1 and 2), and only one support module is allowed to be lifted at each time. Before lifting, confirm whether the pallet and carton are damaged and whether the lifting rope is strong and firm. When lifting is about to land, two people straighten the carton gently on the relatively flat position of the project.

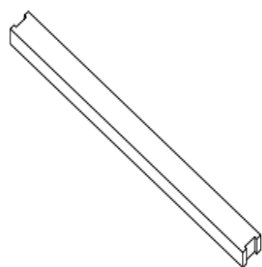

Figure 1 Solid wood support frame

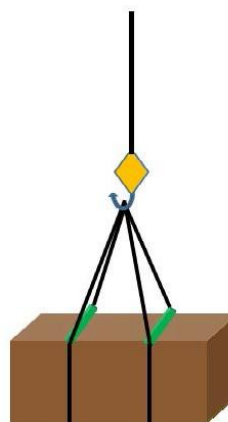

Figure 2 Schematic diagram of lifting

- It is forbidden to stack modules at the project site.
- During the transportation to the project, stacking of modules is prohibited, and only one layer of transportation is allowed.

Safety and transportation

- Warehouse storage at the project site:

Storage environment requirements: Humidity < 85%, temperature -20 °C ~ +50 °C; Static stacking of modules ≤ 2 pallets.

- Temporary storage at the project site: Place the modules in a ventilated and dry place, do not stack them, and cover the modules with waterproof cloth to prevent the modules from getting damp.

Unpacking instructions

1. When unpacking outdoors, it is forbidden to work under rainy conditions;
2. If there is wind on site, special attention should be paid to safety, especially in the case of strong wind. It is recommended not to move the modules and properly fix the unpacked modules;
3. The working surface shall be such that the packing box can be placed in a stable, level position, avoiding being overturned;
4. Please wear protective gloves during unpacking to avoid scratching hands and leaving fingerprints on the glass;
5. It is a normal phenomenon that a small amount of corner protectors fall off due to failure to operate as required or unskilled operation. The role of corner protectors is to protect modules from external force damage during transportation, and the loss of corner protectors does not affect the reliability of modules;
6. Carefully check the product information on the outer box before unpacking, and carefully read the unpacking instructions;
7. Each module needs 2 people to lift. When lifting the module, it is forbidden to pull the junction box.

Mechanical installation

Location selection

Select the appropriate location to install the modules. In the northern hemisphere, the modules need to face south, and in the southern hemisphere, the modules need to face north.

The module installation site shall have sufficient light and will not be shaded at any time. If the module is shaded or partially shaded, its power output will decrease. Prolonged shading or frequent shading causing module damage is not covered by Tongwei warranty.

It is forbidden to store, install or use modules in places where combustible gases are easy to generate or accumulate.

Unless Tongwei agrees in writing or otherwise stated in the contract, the straight line distance between the installation site and the coastline shall not be less than 1 km.

Installation angle

The same string of modules should be installed at the same angle. Modules installed at different angles will obtain different irradiation, resulting in current mismatch, which leads to the decrease of system operation efficiency.

Please refer to Table 1 for the recommended installation angle of modules.

Local latitude	Assembly installation angle
0° ~ 15°	15°
15° ~ 25°	Local latitude
25° ~ 30°	Local latitude + 5°
30° ~ 35°	Local latitude + 10°
35° ~ 40°	Local latitude + 15°
> 40°	Local latitude + 20°

Table 1 Assembly installation angle

Mechanical installation

Installation Requirements

- The installation structure must be made of durable anti-corrosion and anti-ultraviolet materials. Please ensure that the brackets and structures used are tested and certified.
- Wherever the module is installed, it must be ensured that the module is firmly fixed to the bracket and can withstand the corresponding wind and snow pressure loads.
- Choose the appropriate installation height of photovoltaic bracket system to prevent the lower part of the module from being covered with snow for a long time when it snows in winter. In addition, ensure that the lowest part of the module is high enough to prevent the module from being obscured by plants or damaged by flying sand.
- For photovoltaic systems installed on the ground, Tongwei suggests that the minimum distance between the bottom of the module and the ground should be 24 inches (60 cm). The higher the lowest point of the module is from the ground, the higher the power generation efficiency of the back of the module. When the module is installed on the roof, ensure that the roof structure is suitable and that the module does not exceed the roof area after installation. In addition, the roof must be sealed to prevent water leakage.
- If the module is to be mounted on the pillars, the selected pillars and assembly support structure must be able to withstand the local expected wind pressure and snow pressure load. Ensure that the wind and snow loads that the modules may bear are within the maximum wind and snow loads allowed by Tongwei, and will not bear the thermal expansion force of the support structure. Overlapping of modules is prohibited.
- The back of the module should be ventilated smoothly to cool the module. Tongwei suggests that there should be at least 30 cm gap between the module and the mounting surface. At the same time, the surface can be made of light-colored and highly reflective materials such as white paint and aluminum foil, which can make the back of the module achieve an additional income of 5%~30%.
- In order to prevent thermal expansion between modules from affecting modules, Tongwei recommends that the minimum installation distance between two modules should not be less than 10mm, which refers to the minimum linear distance between the glasses of two modules.
- The guidance notes and safety rules attached to module installation must always be followed.
- Do not drill holes in the glass surface or frame of the module, otherwise the warranty will be invalidated.

Mechanical installation

Installation method

- Installation with the mounting clamp

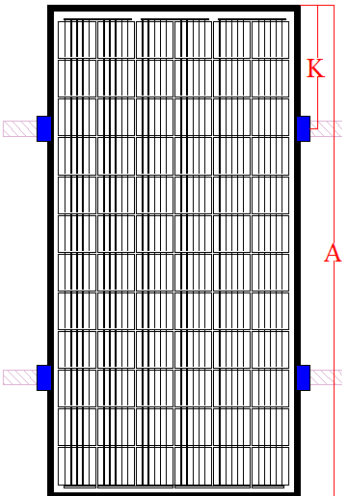
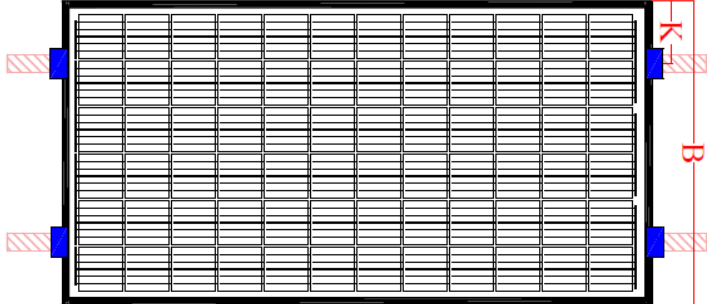
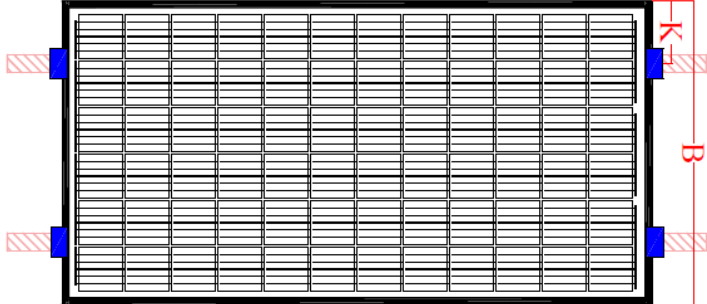
Table 2 Installation Mode	
Long side installation	Installation mode A 
	Installation mode B 
Short side installation	

Note: The length of pressing block is $\geq 50\text{mm}$.

Mechanical installation

Table 3 Installation Mode and Load Capacity

Installation mode		Installation mode A		Installation mode B	
Module model	Module dimensions (mm)	Pressing block position K (mm)	Design load: Front/back, $m=1.5$ (Pa)	Pressing block position K (mm)	Design load: Front/back, $\gamma m=1.5$ (Pa)
TW***MBAP-108-D	1722*1134*30/35	380-480	3600/1600	—	—
TW***MBAP-120-D	1908*1134*30/35	427-572	3600/1600	—	—
TW***MBAP-144-D	2278*1134*30/35	520~620	3600/1600	—	—
TW***MBCP-120-D	2172*1303*35	493~593	3600/1600	275~375	1600/1600
TW***MBCP-132-D	2384*1303*35	546~646	3600/1600	275~375	1600/1600

Note: Test load= γm (safety factor) \times design load

Mechanical installation

- Installation with the mounting hole

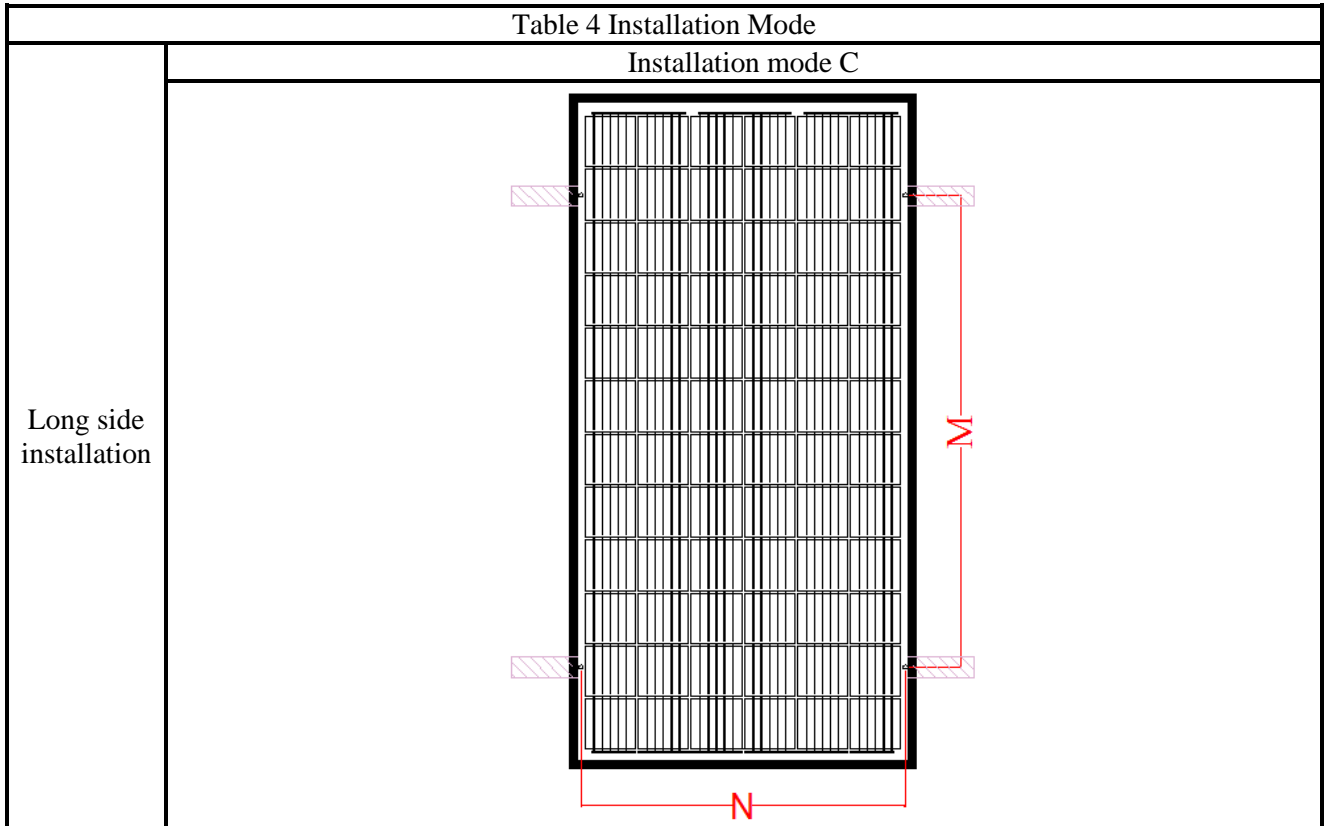

Mechanical installation

Table 5 Installation Mode and Load Capacity

Module model	Module dimensions (mm)	Spacing of mounting holes M(mm)	Spacing of mounting holes N(mm)	Installation mode C Design load: Front/back, $\gamma_m=1.5$ (Pa)
TW***MBAP-108-D	1722*1134*30/35	1400	1085	3600/1600
TW***MBAP-120-D	1908*1134*30/35	990	1085	3600/1600
		1400	1085	3600/1600
TW***MBAP-144-D	2278*1134*30/35	990	1085	3600/1600
		1400	1085	3600/1600
TW***MBCP-120-D	2172*1303*35	—	—	—
		1400	1254	3600/1600
TW***MBCP-132-D	2384*1303*35	—	—	—
		1400	1254	3600/1600

Note: Test load= γ_m (safety factor)×design load

Mechanical installation

Modules can be installed and fixed in the following installation methods;

- Installation of mounting hole: Use corrosion-resistant M8 bolts and fix them to the mounting bracket through the mounting holes on the assembly frame, as shown in Figure 3;
- Installation clip installation: Fix the mounting bracket with the module using the appropriate clamp, as shown in Figure 4.

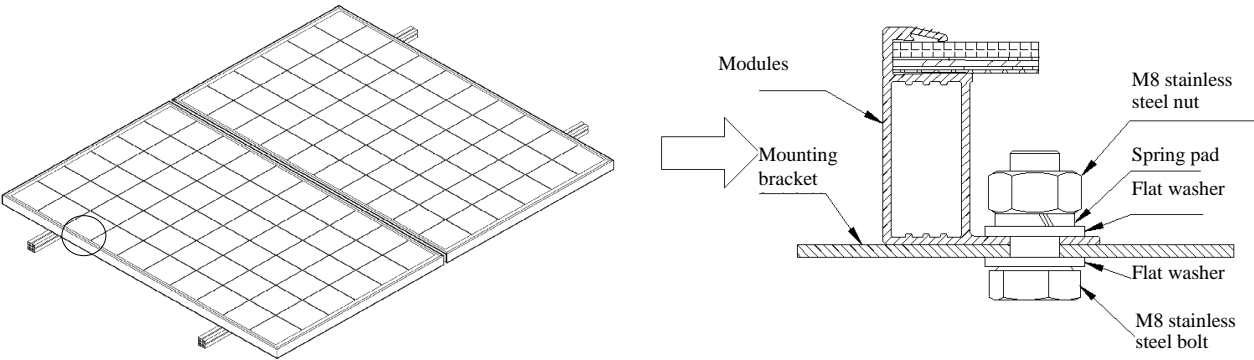

Figure 3 Installation of mounting hole

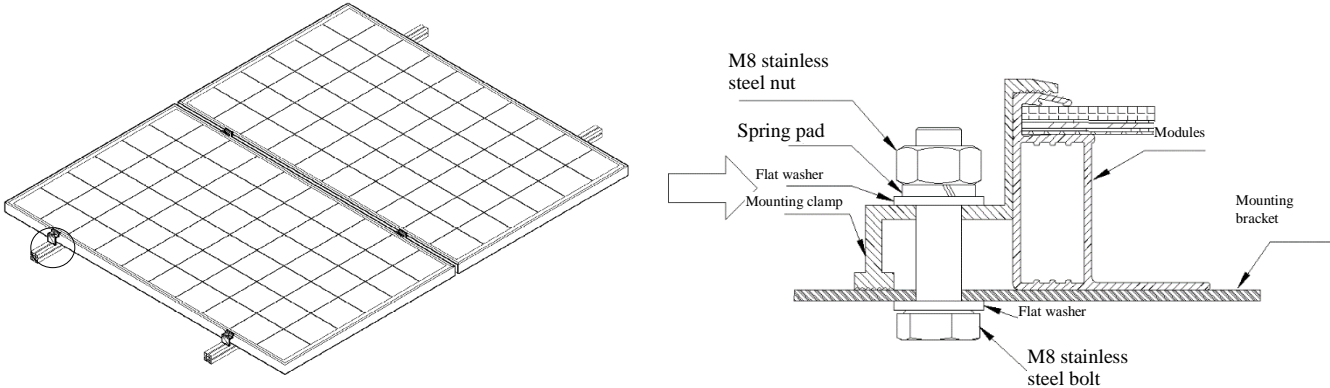

Figure 4 Installation of mounting clip

Recommended accessories are as follows:

Bolts	Flat washer	Spring washer	Nuts
Material: Stainless	Steel type: Stainless steel	Material: Stainless steel	Material: Stainless steel
Size: M8	Size: M8	Size: M8	Size: M8

Torque range of screw tightening: 14N. m to 20N. m.

Electrical installation

The direct current generated by photovoltaic system can be converted into alternating current and sent to the power grid. Policies on connecting renewable energy systems to public power grids vary from region to region. When designing a system, please consult a senior system design engineer for relevant information. Usually, the system installation needs to be approved and officially authorized by the local public utility department.

General rules for electrical installation

- Any mounting structure material used must match the module and any failure resulting from such corrosion will render the warranty invalid.
- According to the needs of the system, the DC side system potential of photovoltaic matrix can be grounded by floating, positive grounding and negative grounding; And different cell technologies have different adaptability. In power station project, if the absolute value of negative potential to ground of crystalline silicon cell module is too large, it may lead to Potential Induced Degradation (PID), so it is suggested to use negative grounding system to make the potential of the circuit positive. Inquire inverter manufacturers for details.
- It is forbidden for non-professional personnel to open the locking nut of the connector. Ensure that the connector is clean, dry and fully connected (the snap-in sound will be heard when fully connected), otherwise arc sparks may occur, which may damage the connector plug or cause a fire.
- Under normal conditions, modules may generate more power than under standard conditions. When determining the accessories of photovoltaic power generation system, such as rated voltage, rated current, wire capacity, fuse specifications and other parameters related to the power output of PV modules, the value of ISC and VOC marked on the modules shall be multiplied by 1.3 times.
- In order to prevent the current generation during the disassembly of conductors, an opaque plastic must be used to completely cover the PV module.
- Do not use different types of modules in the same solar photovoltaic system. When the modules are connected in series, the voltage of each series cannot exceed the maximum voltage of the system (the series connection mode is shown in Figure 5 below). Reference formula of maximum series number of modules: $\text{Maximum system voltage of modules} / (1.3 * \text{open circuit voltage})$.
- When connected in parallel, the output current of the whole series of the modules is equal to the current sum of each branch module or module series (parallel connection mode is shown in Figure 6). Each series of modules should be fused. Please refer to the national or local specifications. Refer to the formula for the maximum number of modules connected in parallel: $\text{Maximum protection current} / (1.3 * \text{short circuit current})$.

Electrical installation

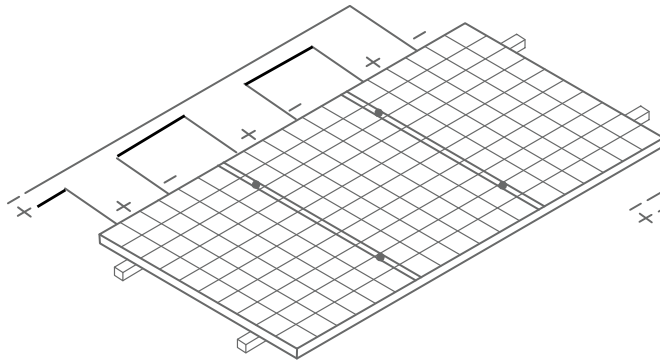

Figure 5 Series connection mode

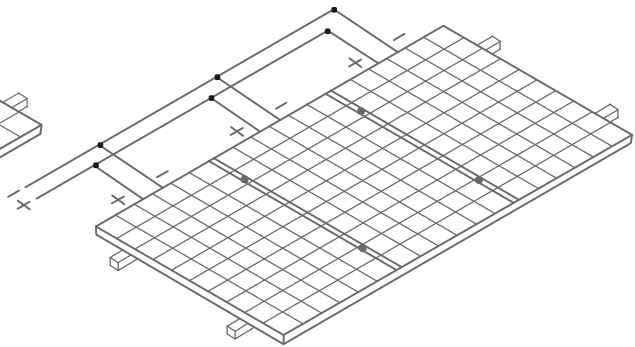

Figure 6 Parallel connection mode

- Please refer to local regulations to determine the wire size, type and temperature of the system.
- The cable cross section and connector capacity that adapt to the maximum short circuit current of the system must be selected (the recommended cable cross section area for a single module is 4 mm^2 and the rated current of the connector is recommended to be greater than 20A), otherwise the cable and connector will overheat in the case of excessive current. Note: The maximum temperature of cables is $85 \text{ }^\circ\text{C}$, and the maximum temperature of connectors is $105 \text{ }^\circ\text{C}$.
- During the installation of the module, please make sure that the connector, inverter and other electrical components are in closed state. In order to reduce the damage caused by lightning strikes, the loop area must be kept as small as possible when laying cables, and it is recommended to use appropriate fuses for each series.

Grounding

- Grounding wire matching with the bolt installation
- Grounding bolts must be made of stainless steel and used on designated grounding holes. First insert the M3.5 stainless steel bolts through spring washer, flat washer, cup washer (2.1 mm diameter copper wire), star washer, then through the ground hole of the frame, flat washer, spring washer, and finally tighten with M3.5 nuts, please note: The upper limit of conductor temperature is 85 °C, and the installation is shown in Figure 7.
- Installation of connecting nose matching with bolts
- All module frames and mounting brackets must be properly grounded in accordance with relevant national electrical regulations. Use the recommended connection terminals and connect the grounding cable well and fix it to the module frame.
- If the bracket used is made of metal, the surface of the bracket must be plated to ensure good circuit conduction.
- A suitable grounding effect can be achieved by connecting the module frame to the bracket with a suitable grounding conductor.
- The grounding conductor must be connected to the ground through a suitable grounding electrode. It is recommended to connect the grounding cable with a connecting nose. If it is not connected by bolts and nuts, only mechanically connected to the grounded module, the bracket must also be grounded.
- First, strip the grounding cable head for a proper length. Pay attention not to damage the metal wire core during the stripping process, and insert the stripped grounding cable head into the socket of the connection nose, and then tighten the fasten screw. Connect the connection nose to the aluminum frame using stainless steel bolts and connectors as shown in Figure 8. The recommended tightening torque for M3 bolts is 2.3 N · m.

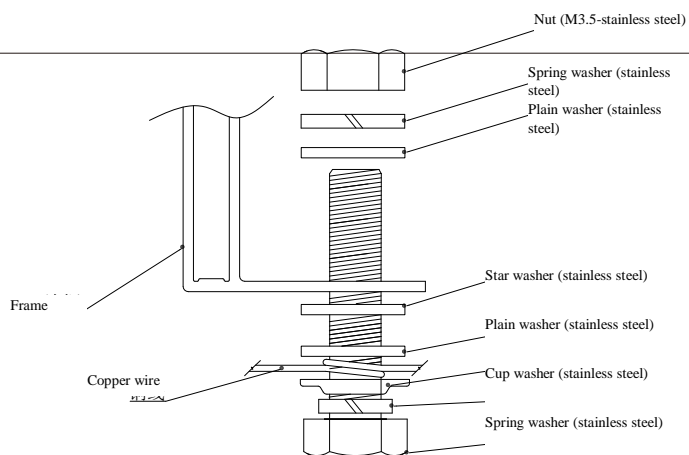

Figure 7

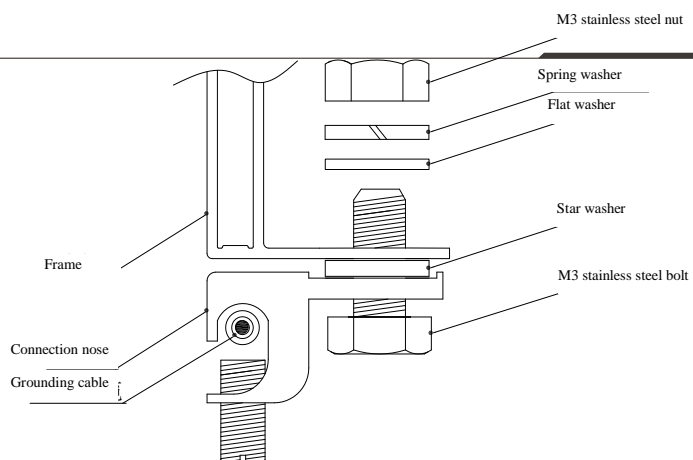

Figure 8

Bypass diode and anti-reverse diode

In a system with two or more modules in series, if some modules are shaded while others face the sun, a very high reverse current will pass through the partially or completely covered cell, which will cause the cell to overheat and may damage the modules. By using bypassing diodes, modules can be prevented from such risks. There are bypass diodes in the junction box, which can reduce the partial shadowing effect. It is forbidden to disassemble the junction box privately to replace the diode, even when the diode is damaged. Such work should be performed by professionals.

In a photovoltaic cell-equipped system, if the controller does not have backswing protection, the anti-reverse diodes installed between the cell and the assembly can prevent reverse current from damaging modules.

Maintenance

Modules are normally maintenance-free. The following maintenance measures are recommended to ensure the best performance of modules:

In most cases, the normal amount of rainwater is enough to keep the module glass clean. If necessary, clean the glass surface with a wet sponge or rag, and use a neutral anti-wear cleaner to remove intractable dirt.

If the glass or back plate of the module is perforated, please do not clean it. Such modules have a serious risk of electric shock. Conduct regular mechanical and electrical inspection to ensure that the joints of modules are clean, reliable and free from damage and corrosion. Tongwei recommends that the inspection frequency should be once every 6 months.

When the maintenance personnel open the connection, make sure that the parts are in good condition, otherwise the connector must be replaced, and the damage of the connector will easily lead to electric leakage. Nut tightening torque is 1.5 Nm-3 Nm.

When repairing the module, please cover the surface of the module with opaque material to prevent electric shock. Modules exposed to sunlight will produce high voltage, please pay attention to safety when repairing, and must be carried out by professionals.

Warning: MUST first shut down the photovoltaic system for any electrical maintenance. Improper system maintenance may lead to fatal hazards such as electric shock and combustion.